

Machining Centre

Machines for processing aluminium and PVC profiles

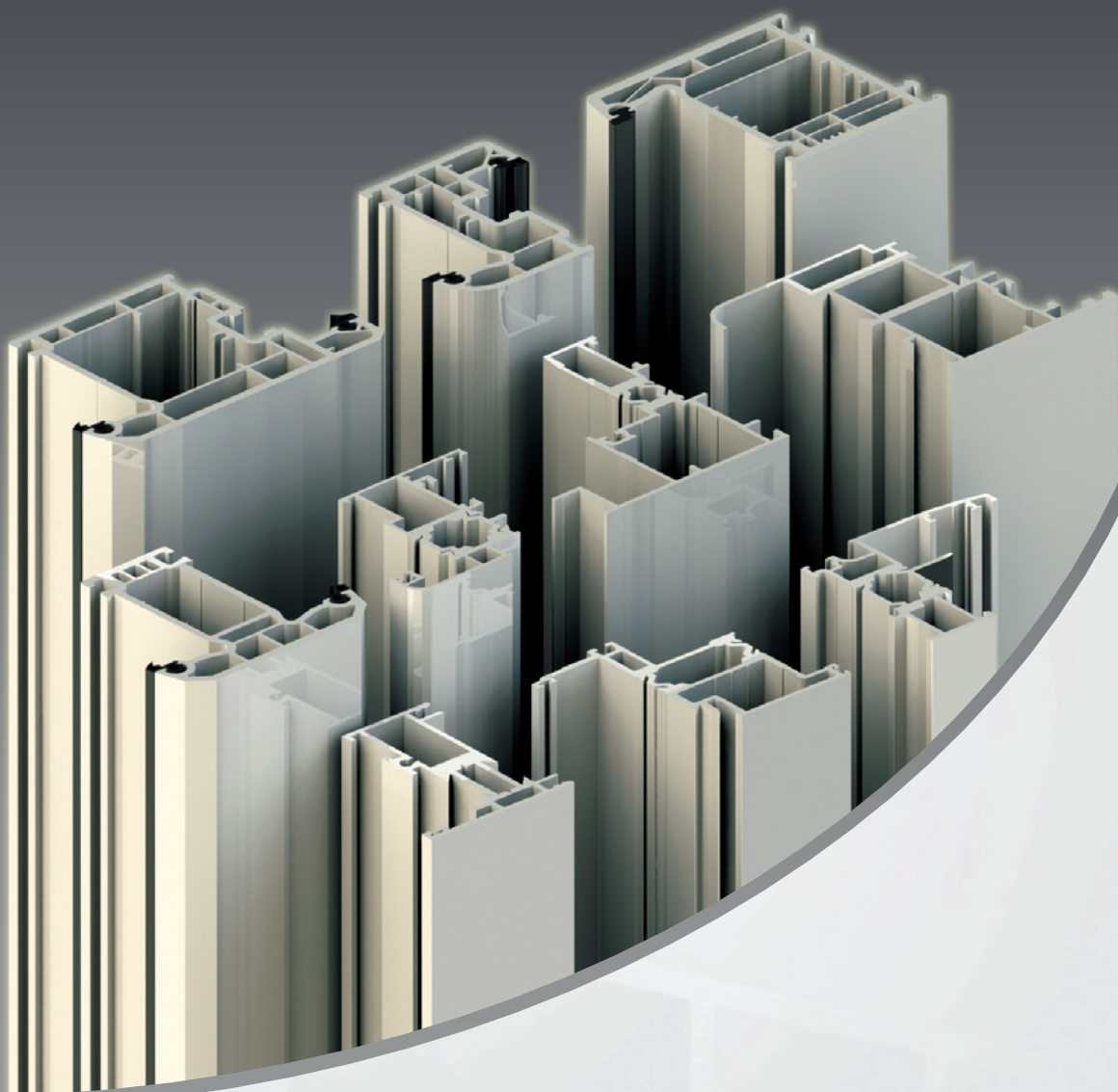

Machines fully designed and manufactured in Italy

PERTICI
INDUSTRIES

THE COMPANY

Pertici Industries, was founded in 1965 by Leto Pertici as Costruzioni Meccaniche Pertici.

Originally, the Company started off with the production of traditional wood-working machines and subsequently developed the production of machinery for the aluminium and PVC door and window industry.

Pertici has always been a competent and reliable supplier of machinery for the production of windows and doors with a range of products constantly developed and improved.

The volume growth and the extension of the production site, accompanied by a production cycle completely controlled inside, allowed Pertici to offer solutions of the highest quality and reliability able to meet the needs of every type of customer.

Thanks to these characteristics, since the eighties, Pertici has been the protagonist of a strong international expansion that allowed the creation of a solid distribution network around the world. In nearly fifty years of work, Pertici has installed tens of thousands of plants in Europe, America, Africa, Asia and Australia.

Today Pertici Industries is a world leader in the design and construction of machines and systems for the processing of aluminium and PVC profiles. Pertici develops and implements cutting-edge technology guaranteeing a global customer service which includes servicing, maintenance, installation, support and timely educational training.

The expertise and experience embedded in all the staff together with the strong presence in the global market are essential elements of the company constant development strategy.



PERTICI WORLDWIDE



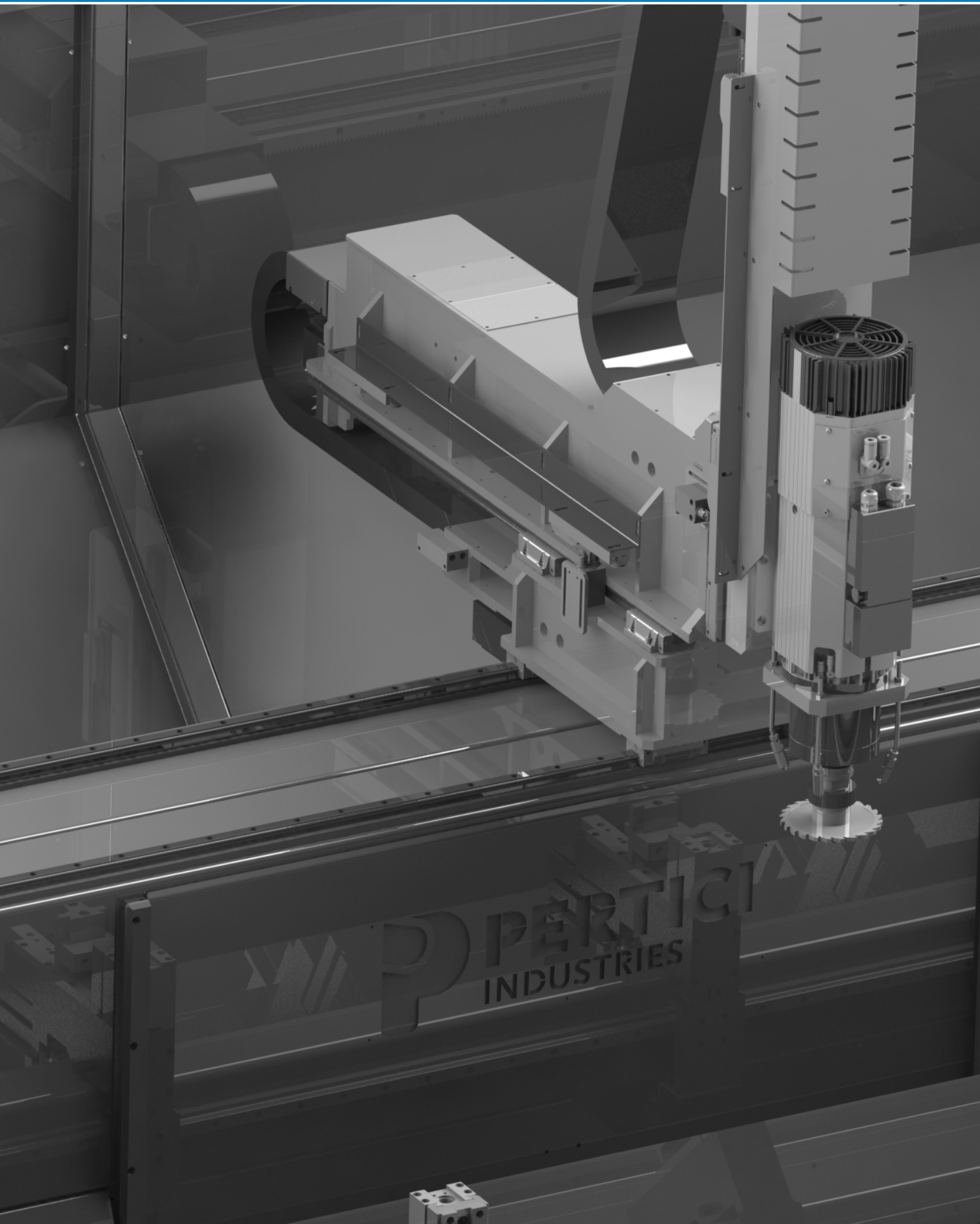

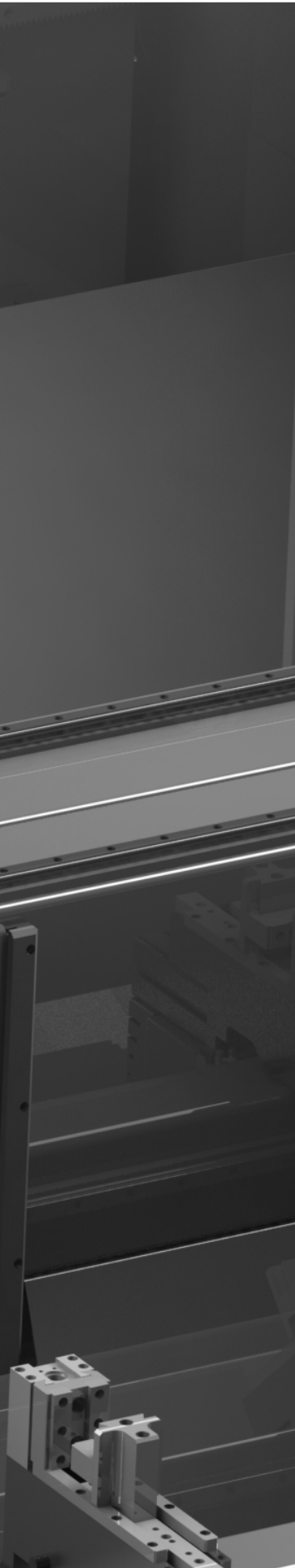

Machining centre

CNC vertical machining centre is designed for drilling, milling and copying operations suitable for several materials:

- aluminium profiles,
- steel profiles,
- PVC profiles (including steel reinforced pvc profiles),
- various plastic materials.

It is used for several applications, where the aluminum is widely used particularly manufacturing of windows, doors, and curtains walls.

The machining head moves in longitudinal, transversal and vertical directions by BRUSHLESS motors with rack and pinion system allowing the movement on ball bearings rails and slides to achieve very high precision.







The rotation of the table between -90° to $+90^{\circ}$ (except for MC 400E model) and the angular head allows machining operation on all faces of the profile at any angles.

The MC machining centre offers an user friendly software available on board and at the office.

Three models are available according to various length and versions to meet customer needs.

Models

pag

Machining centre MC 700A	 	6
Machining centre MC 400	 	8
Machining centre MC 250	 	10

Machining centre MC 400

- **3/4 CNC controlled axis**
- X axis maximum travel (longitudinal): 4175 mm
- Y axis maximum travel (transversal): 500 mm
- Z axis maximum travel (vertical): 490 mm
- A axis maximum travel (only for models having rotating table): $-90^{\circ} \div +90^{\circ}$
- X Axis drive max speed: 90 m/min
- Y Axis drive max speed: 60 m/min
- Z Axis drive max speed: 60 m/min
- Rotating table drive max speed (if present): $90^{\circ}/s$
- Electrospindle power: 5,5 kW
- Electrospindle maximum speed: 18000 rpm
- Tool store (if present): 8 tools with possibility to host 2 angular heads and 1 milling blade
- Tool change: automatic/manual (according to the model)
- Maximum diameter of milling tool: 20mm
- Milling blade maximum diameter: 180mm
- Number of standard clamps: 4
- Adjustment of clamps positioning: automatic/manual (according to the model)
- Number of end stops: 2
- Minimal lubrication system
- Automatic front protection door
- Power supply: 8,5 kW (12 kW for 7,5 kW electrospindle)
- Air consumption: 150 NI/
- Dimensions (length x depth x height):
 - 5373 x 2550 x 2437 mm
- Weight: 2500 kg

Control features

- Windows 7 operating system
- Advanced 3D software
- HMI (Human Machine Interface): display of axis positions, clamps, electrospindle rotation, control of axis jogs, lubrication, etc.
- Tools Table: for storing the parameters of the tools used during machining.
- CNC Setting Tables: machine parameters tables for adjusting the configuration and for maintenance of the machine (axis lengths, origins, number of clamps, machine mapping for software correction, etc.)
- Macros programming
- Parametric functions
- Inclined planes management
- Profile extrusion with DXF files sections
- On board PC Hardware includes:
 - Colour Monitor LCD 17"
 - Ethernet card for network connection
 - Serial port and USB port
 - SSD
 - USB port, Memory Data Storage

Options

- Additional clamps: max n. 2
- Electrospindle power: 7,5 kW (max speed: 24000 rpm)
- Bar code reader
- Empowered lubrication system
- Air cooling system
- Blinking light to indicate the working status (program completed, in operation, in emergency)
- Tool setting and breakage detection
- Dust Exhausting System
- Machine Full Enclosure
- Angular head

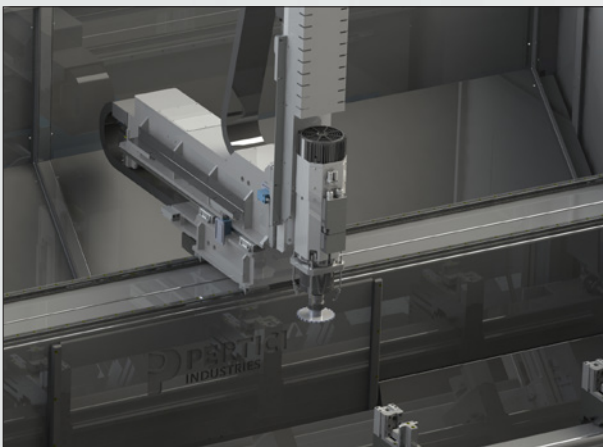

MC 400A

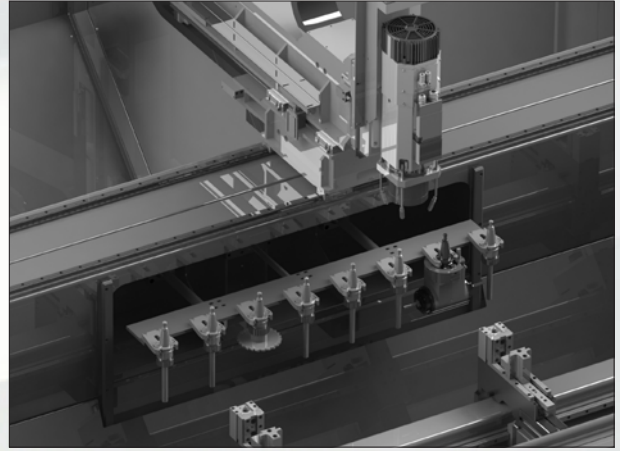
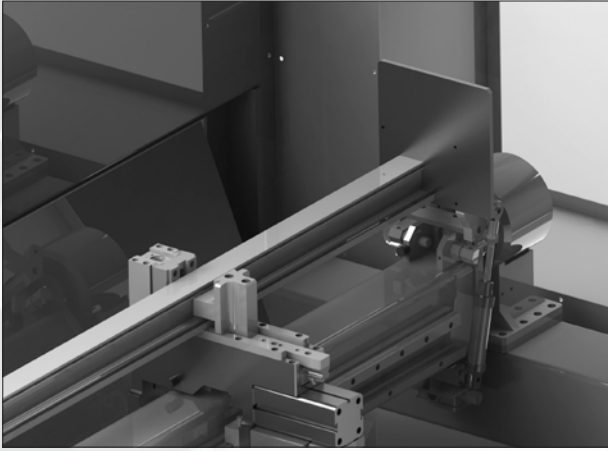

Models	CNC controlled axis	Table	Clamps positioning	Tool change
MC 400A	4 (X-Y-Z-A)	rotating CNC controlled	automatic	automatic with tool storage
MC 400B	4 (X-Y-Z-A)	rotating CNC controlled	by operating head	automatic with tool storage
MC 400C	4 (X-Y-Z-A)	rotating CNC controlled	manual recommended	manual
MC 400E	3 (X-Y-Z)	fixed	manual recommended	manual

